EFNh 9471

Integrated freezer with NoFrost

LIEBHERR

Fully Integrated



Fully Integrated

LIEBHERR

EFNh 9471

Integrated freezer with NoFrost



↑
213
↓



Type	Fixed door / Built-in appliance for integrated use
Energy consump. in 365 days/24 h	355 kWh
Total volume	245 l ¹
Frequency / voltage	50/60 Hz / 220-240 V~
Connection Rating	2.0 A 120.4 W
Aperture dimensions in cm (h / w / d)	213.4 / 45.7 / min. 63.5
Controls	
Type of Control	3.5" LCD colour display, behind the door, touch- & swipe Digital temperature display
Interface	SmartDeviceBox: optional accessory (Only available in selected countries)
Door alarm	acoustic
Alarm in case of malfunction	visual and acoustic
Forced air system	PowerCooling
Freezer compartment	
Star coding	****
Interior light	InfinityLight
Number of drawers	3 drawers with SoftTelescopic
IceMaker	with fixed 3/4" water connection, LED lighting
Ice cube capacity in 24 hours	- kg
Ice cube stock	1.8 kg
Ice cube tray	1
Features	
Door hinges	Reversible door hinge, left
Replaceable door seal	yes
EAN-Nr.	9005382276570

¹ In accordance with Regulation EU 2019/2016 we indicate the total volume to the nearest integer (rounded off) and the volume of the frozen compartments and refrigeration compartments to one place after the decimal point.

Features



German Engineering

Our superior products offer premium quality, cutting edge design, and innovative features that best fit your lifestyle. The use of high quality materials, perfectly detailed finishes, and elite cooling components are combined with the latest production processes, resulting in an outstanding cooling product.



NoFrost

The Monolith also impresses with maximum comfort at sub-zero temperatures. Its NoFrost technology always keeps the freezer compartment free of ice and prevents food from becoming covered in frost. It makes defrosting a thing of the past.



SmartDevice

Your Liebherr may well be standing in the kitchen – but if you want, it can also be connected to the Internet at any time. The SmartDeviceBox opens the door to all the Smart Home benefits. Simply plug it in, switch it on and connect your Liebherr to the network via WiFi. The Monolith is supplied with a SmartDeviceBox.

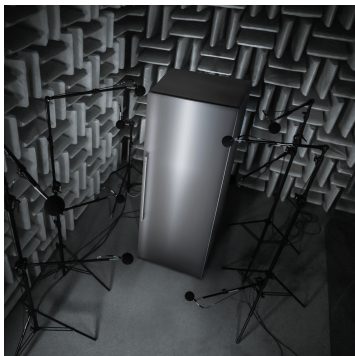

SuperQuiet

Noise levels are kept to a minimum thanks to virtually silent, speed-controlled, and sound absorbing compressors. Alongside a low noise cooling circuit, these features ensure exact performance, energy efficiency, and SuperQuiet operation.

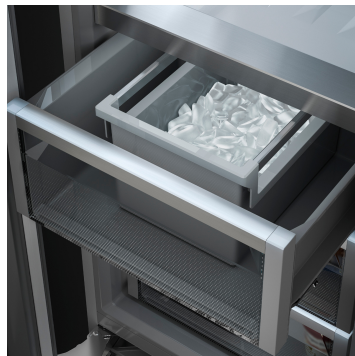

IceMaker

Monolith's automatic IceMaker produces 1.6 kg (3.5 pounds) of filtered ice in 24 hours. Activate the SuperFrost function for an even greater production capability. With a 1.8 kg (4-pound) storage capacity, you'll never be without.



InfinitySwipe

For a touch more comfort, the user-friendly InfinitySwipe electronic touch control with a bright and clear 3.5-inch display can be operated intuitively and effortlessly via touch & swipe.

Technical drawing

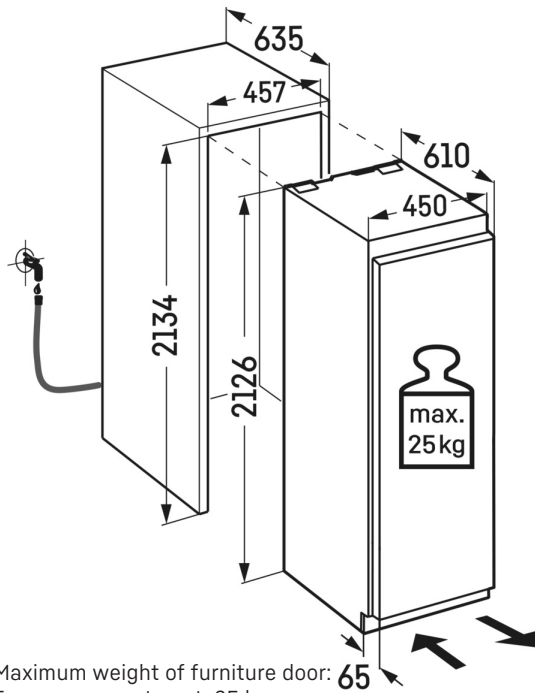

Maximum weight of furniture door: 65
Freezer compartment: 25 kg

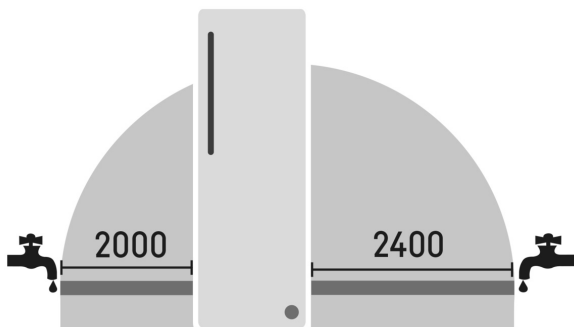

Products and their details are staged for advertising purposes. Whilst every effort is made to ensure all specifications and information in this flyer are accurate, Liebherr reserves the right to make changes without notification. Where actual appliance measurements, specifications, and ratings are crucial, we recommend that the actual appliance installation instructions that accompany each appliance be checked. Liebherr will not be liable for any damage. (21.03.2025)

